

**2015 NDIA GROUND VEHICLE SYSTEMS ENGINEERING AND TECHNOLOGY
SYMPOSIUM
VEHICLE ELECTRONICS AND ARCHITECTURE (VEA) TECHNICAL SESSION
AUGUST 4-6, 2015 - NOVI, MICHIGAN**

**MODULAR OPEN RF ARCHITECTURE:
EXTENDING VICTORY TO RF SYSTEMS**

Adam Melber

U.S. Army, RDECOM CERDEC I2WD
Aberdeen Proving Ground, MD

Jason Dirner

Vistrionix, Inc.
Aberdeen Proving Ground, MD

Michael Johnson

Northrop Grumman Corporation
San Diego, CA

ABSTRACT

Radio frequency products spanning multiple functions have become increasingly critical to the warfighter. Military use of the electromagnetic spectrum now includes communications, electronic warfare (EW), intelligence, and mission command systems. Due to the urgent needs of counterinsurgency operations, various quick reaction capabilities (QRCs) have been fielded to enhance warfighter capability. Although these QRCs were highly successfully in their respective missions, they were designed independently resulting in significant challenges when integrated on a common platform.

This paper discusses how the Modular Open RF Architecture (MORA) addresses these challenges by defining an open architecture for multifunction missions that decomposes monolithic radio systems into high-level components with well-defined functions and interfaces. The functional decomposition maximizes hardware sharing while minimizing added complexity and cost due to modularization. MORA achieves significant size, weight and power (SWaP) savings by allowing hardware such as power amplifiers and antennas to be shared across systems. By separating signal conditioning from the processing that implements the actual radio application, MORA exposes previously inaccessible architecture points, providing system integrators with the flexibility to insert third-party capabilities to address technical challenges and emerging requirements.

MORA leverages the Vehicular Integration for Command, Control, Communication, Computers, Intelligence, Surveillance, and Reconnaissance (C4ISR)/EW Interoperability (VICTORY) framework. This paper concludes by discussing how MORA, VICTORY and other standards such as OpenVPX are being leveraged by the U.S. Army Research, Development, and Engineering Command (RDECOM) Communications Electronics Research, Development, and Engineering Center (CERDEC) to define a converged architecture enabling rapid technology insertion, interoperability and reduced SWaP.

Keywords: VICTORY, MORA, CERDEC, Architecture, Convergence, Multifunction, Interoperability, Radio

INTRODUCTION

Today, the increasing radio frequency (RF) multifunction requirements of ground based mounted and dismounted systems as well as small unmanned aerial vehicles are causing size, weight, and power (SWaP) challenges. Figure 1 illustrates the multitude of electronic systems that are integrated on Army vehicles. Many of these systems have arisen from the urgent operational needs of the conflicts in Iraq and Afghanistan. These quick reaction capabilities have been successfully integrated and have greatly enhanced the war fighting capability. However, these systems were designed independently with unique power supplies, transceivers, power amplifiers, antennas, user interfaces, and training. Although they all individually passed Army test and evaluation before deployment, they were in some cases used together for the first time in theater. In addition to the challenges noted above, certain functions proved to not be compatible. In particular, RF emissions from the electronic warfare systems compromised communications performance resulting in “Blue Force RF Fratricide” [1].

This legacy approach of federated “stovepiped” systems has limitations which include the following:

- Inability to perform rapid technology insertion to address emerging threats and keep pace with commercial technology.
- Inordinate consumption of SWaP due to parallel sets of (often already-redundant) GPS receivers, power amplifiers, antennas, filters, user interfaces, and the like.
- Independent concurrent operation of RF devices across overlapping frequency bands, which can result in RF cosite interference.
- Closed systems and interfaces, which create vendor lock-in and reduced competition for maintenance, resupply

due to attrition, upgrades, and user training.



Figure 1. Legacy stovepiped systems consume an inordinate amount of SWaP on Army vehicles.

MODULAR OPEN RF ARCHITECTURE

Approach

Communications-Electronics Research, Development and Engineering Center (CERDEC) Intelligence and Information Warfare Directorate (I2WD) in conjunction with industry partners such as Northrop Grumman Corporation is developing the Modular Open RF Architecture (MORA) to address the challenges of today’s stovepiped systems. MORA defines an open architecture for multifunction missions that decomposes monolithic radio systems into high-level components with well-defined functions and interfaces. The functional decomposition selected maximizes hardware sharing while minimizing added complexity and cost due to modularization. As power amplifiers (PAs) and antennas are some of the biggest consumers of SWaP on the platform, MORA achieves significant SWaP savings by allowing them to be shared across systems. By separating these signal conditioning components from signal processing

components that implement the actual radio application, MORA exposes points in the architecture that were not previously accessible. This in turn provides system integrators with the flexibility to insert third-party capabilities to address technical challenges and emerging requirements. Such capabilities may include interference cancellation techniques to address Blue Force RF Fratricide resulting from today's independent operation.

Separating components such as PAs which require greater heat dissipation allows system integrators to place them in areas with better cooling and airflow. Ideal places such as outside the platform are now possible as these semi-perishable components are decoupled from more sensitive and expensive components which are still located inside the platform. Co-locating PAs and antennas further reduces power consumption by minimizing the length of high power runs and associated cable loss. Overall system efficiency and performance is thereby improved by requiring less power to achieve the same over-the-air (OTA) effects. Routing low power RF signals between components within the platform enables hot switching at rapid speeds which is required for time switched sharing of PAs and antennas. Resulting capabilities include transmit diversity which mitigates multipath interference by transmitting the same signal from two or more antennas. Although this is not a new technique, it is now possible without additional SWaP as systems can share the same antennas. Routing low power cables also facilitates system installation due to better cable bend radius and smaller cable diameter (resulting in smaller holes).

By divorcing specific capabilities (i.e., radio applications) from the hardware they run on, MORA makes hardware a commodity that can be dynamically configured based on mission objectives. Because most RF applications have the same underlying

hardware requirements, a radio's personality can be changed simply by provisioning it with new software. Although the concept of a software defined radio (SDR) is not unique to MORA, the standardized interfaces that MORA defines enable monitoring and management of SDRs via common user interfaces and platform automation. Use of common hardware allows system integrators to establish pooled resources that provide varied levels of availability. A dedicated spare can be included to tolerate the failure of a single component without any loss of capability. On platforms where redundancy is not an option, MORA allows the warfighter to select which capability is lost by preempting a lower priority mission. As an example, the warfighter may choose to repurpose a communications radio as a jammer to restore the counter-IED mission.

Architecture Overview

MORA leverages to the maximum extent possible the Vehicular Integration for C4ISR/EW Interoperability (VICTORY) architecture [2] and specifications [3]. The VICTORY initiative is developing a framework to enable the integration of Command, Control, Communications, Computers, Intelligence, Surveillance, Reconnaissance (C4ISR) and Electronic Warfare (EW) systems on U.S. Army ground vehicles. The central structure of the VICTORY architecture is an Ethernet-based vehicle network called the VICTORY Data Bus (VDB). Shared data services foster commonality by providing information required by most C4ISR/EW systems such as time synchronization, position, orientation, and direction of travel. Shared hardware devices reduce SWaP impact by allowing systems to use common processing resources and user interface devices. The Information Assurance (IA) architecture enables "defense in depth" security designs and supports many IA requirements and levels. Access control

services provide authentication of entities and authorization for access to resources which becomes increasingly important as current-force systems move towards network-centricity.

The VICTORY architecture is organized into component types based on functionality such as audio data source, video or image sensor, EW device, and voice/data radio. Each component type includes network-based messaging interfaces for data transport, data dissemination, health publishing, and auto-discovery. Data transport interfaces specify transport layer and lower protocols including Ethernet and Internet Protocol (IP).

Data interfaces define higher layer protocols for application data format and encoding that primarily use eXtensible Markup Language (XML) encapsulated in User Datagram Protocol (UDP). Management interfaces enable configuration and control using SOAP-based web services. Health publishing interfaces provide status reporting and fault management using the Syslog protocol. Zero Configuration Networking (Zeroconf) rounds out the interfaces by providing service and node auto-discovery to enable plug-and-play functionality. Figure 2 illustrates some of the component types defined in the VICTORY architecture.



Figure 2. The VICTORY architecture defines component types for C4ISR/EW systems. Other component types include VDB component types and platform systems. Figure taken from the VICTORY Training Material [4].

MORA extends VICTORY by decomposing a monolithic radio system into SDRs, Radioheads, and an RF Distribution Device (RFDD). Each SDR is connected to one or more Radioheads using RF cables and an RFDD. Configuration, control and health monitoring of each device occurs over the VDB. The MORA High Speed Bus (MHBS) supports ultra-low latency, highly deterministic messaging for real-time communications between components. A power bus completes the architecture by

providing standard vehicle power to each device. The MORA architecture is illustrated in Figure 3.

MORA High Speed Bus

The MORA High Speed Bus (MHBS) extends VICTORY by introducing an addressable bus for real-time communication. The MHBS provides deterministic message delivery with ultra-low latency (i.e., sub-microsecond). Latency

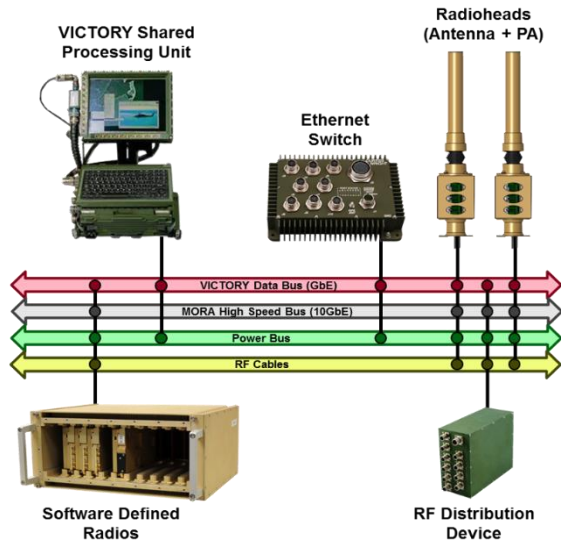

Figure 3. MORA extends VICTORY to decompose monolithic radio systems into high-level components with well-defined interfaces.

is defined as the overall time to send/receive a message and includes transmission, propagation, and switch delays. The MHSB replaces current point-to-point discrete signals (e.g., transistor-transistor logic) between MORA components. Specific uses of the MHSB include transmit/receive switching, blanking, and tuning messages. Use of an addressable bus vice point-to-point signals improves scalability of the MORA architecture and enables component distribution throughout the platform.

The initial instantiation of the MHSB uses 10 Gigabit Ethernet (10GbE) due to its ubiquity in commercial products. As “when” a device can send a message is as important as “how long” it takes for the message to be delivered, deterministic protocols that use a scheduling approach are not appropriate as they limit the maximum message rate. MORA achieves pseudo-deterministic message delivery by using a “fat pipe” to send a very small amount of information. As current discrete signals typically convey binary data (i.e., 0 or 1), it is anticipated that most high speed messages will fit within a

minimum size Ethernet frame (i.e., 64 bytes). The resulting bus usage will only be a fraction of the available bandwidth even at high message rates, thus reducing the probability that collisions will occur and introduce additional delay. This probability is further reduced by the fact that most commercial switches are able to switch at line rate which limits the potential for collision to traffic to/from the same device.

As 10GbE is an optional data-link protocol for the VDB, it is hoped that the VDB and MHSB will eventually be able to share the same physical media. Future versions of the MORA architecture will identify the quality of service (QoS) settings required to prevent non real-time management traffic from degrading the performance of real-time high speed messages. 40 Gigabit Ethernet (40GbE) will be considered if additional bandwidth is required to maintain the pseudo-deterministic delivery of the MHSB.

RF Cables

MORA uses low power RF cables (i.e., maximum power of 100 mW) to connect the RFDD to SDRs and Radioheads. RF cables can either be coaxial cable or optical fiber. Use of less bulky optical fibers facilitates platform integration while improving resistance to electromagnetic interference (EMI). Some instantiations of the MORA architecture may use digital RF as an alternate to analog RF distribution. CERDEC is currently evaluating the use of VITA Radio Transport (VITA 49.2) as the transport-layer protocol for digital RF, including the definition of packets classes to maximize interoperability between independent implementations. Digital RF distribution improves system efficiency by minimizing power loss due to coaxial cables. In this case, it is expected that digital RF data will be sent over the MHSB, thus eliminating the need for separate RF cables. Figure 4 illustrates the “simplified” MORA

architecture when using digital RF distribution.

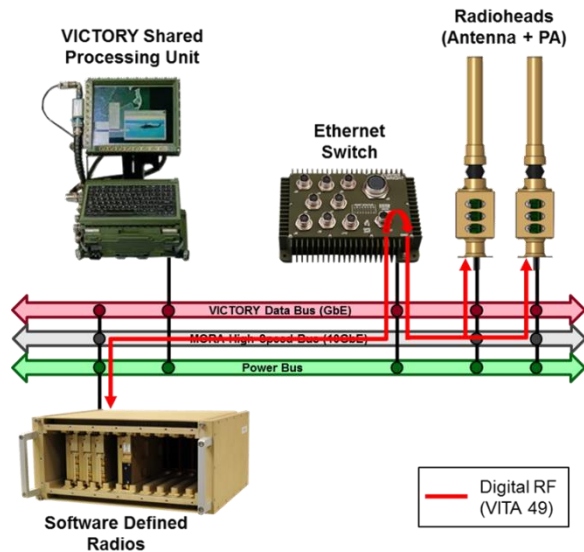

Figure 4. Digital RF distribution simplifies the MORA architecture by eliminating the need for RF cables and an RF Distribution Device.

Software Defined Radio

The Software Defined Radio (SDR) component type implements all of the signal processing for the radio system. Radio applications are implemented in software on any combination of general purpose processor (GPP), digital signal processor (DSP), graphics processing unit (GPU), and/or field programmable gate array (FPGA). Applications can range from passive waveforms (i.e., receive only) such as Global Positioning System (GPS) receivers to active waveforms (i.e., transmit/receive) such as tactical communications. An SDR will have an analog front-end if using analog RF distribution. This front-end will perform the necessary signal conditioning (e.g., RF tuner, digitizer, etc.) to generate a modulated passband signal, which is then transmitted over RF cables to the RFDD. An SDR that leverages digital RF distribution will not

have an analog front-end, but instead will transfer digital RF packets over the MHSB.

An SDR includes a management interface that supports functions for configuration, control, and health monitoring over the VDB. Configuration functions allow an application to be deployed and provisioned over the network, including the ability to select the running application from previously installed options. Control functions allow the operational state of the SDR to be altered over the network. This includes functions such as powering on or off, setting the device in operate or standby, and remotely zeroizing the device. Health monitoring functions allow status and fault information to be provided to entities on the VDB, such as the health of the device's subsystems (i.e., transmitter, receiver, etc.) or general operating conditions (e.g., time synchronization, temperature, etc.).

Radiohead

The Radiohead component type implements most of the signal conditioning for the radio system including PAs, low-noise amplifiers (LNAs), and tunable filters. The Radiohead also contains one or more antennas that serve as the high power OTA interface for the radio system. These antennas may be omnidirectional as is typical with terrestrial communications today, or directional to improve co-site interference or cover larger distances. A lower power interface connects the Radiohead to the RFDD over RF cables when using analog RF distribution. A Radiohead that leverages digital RF distribution will transfer RF packets over the MHSB instead of RF cables. This Digital Radiohead will contain an analog front-end and digitizers, and thus begins to resemble a traditional RF tuner.

A Radiohead includes a management interface that supports functions for configuration, control, and health monitoring over the VDB. Configuration functions

support band selection based on the running application, and allow the gain to be changed to support low power and high power modes of operation. Control functions allow the operational state of the Radiohead to be altered over the network. This includes functions such as powering on or off, as well as setting the device in operate or standby. Health monitoring functions allow status and fault information to be provided to entities on the VDB, such as the health of the device's subsystems (i.e., antennas, amplifiers, etc.) or general operating conditions (e.g., power consumption, temperature, etc.).

Radio Frequency Distribution Device

The Radio Frequency Distribution Device (RFDD) component type consists of an RF switch matrix that connects any SDR to any Radiohead. The simplest instantiation of an RFDD only allows an SDR to be connected to a single Radiohead and vice-versa (i.e., one-to-one). More sophisticated RFDDs may perform signal splitting/combining (i.e., one-to-many) to allow multiple SDRs to share a single Radiohead or support multiple-input and multiple-output (MIMO) configurations. An RFDD should be able to perform hot switching at rapid speeds for low power signals to support time switched sharing of Radioheads. Some RFDDs may also support high power signals at the expense of longer switching times. An RFDD is only required when using analog RF distribution.

An RFDD includes a management interface that supports functions for configuration, control, and health monitoring over the VDB. Configuration functions allow RF connections to be created and removed, and provide a way to specify automated switching tasks that are driven by MORA High Speed Messages (MHSMs). Control functions allow the operational state of the RFDD to be altered over the network, which includes functions to administratively disable

individual ports. Health monitoring functions allow status and fault information to be provided to entities on the VDB, such as the health of the device's ports or general operating conditions (e.g., power consumption, temperature, etc.).

REFERENCE IMPLEMENTATION

Overview

In a joint effort between CERDEC, Northrop Grumman, and Vistrionix, a MORA reference implementation was developed and demonstrated. The system hardware (illustrated in Figure 5) included 2 Northrop Grumman Freedom-series SDRs as the waveform generators, 2 Radioheads based on legacy PAs, and a custom-built 2x2 RFDD.

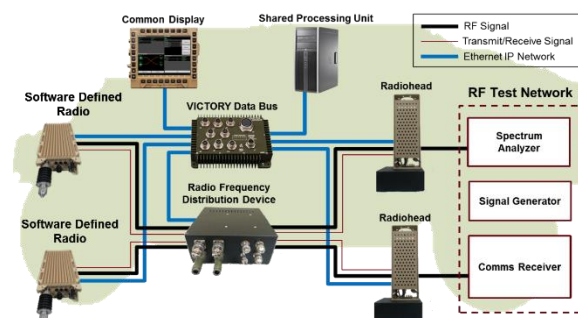

Figure 5. The MORA reference implementation was developed to validate the architecture and demonstrate four operationally relevant scenarios.

The VICTORY Data Bus was run over an Ethernet switch alongside the high-speed discrete and RF networks, which were switched in parallel inside the RFDD. It should be noted that the next version of the reference implementation will replace the discrete signals with real-time messages sent over the MORA High Speed Bus (MHSB). Both the Radioheads and RFDD were augmented with commercial off-the-shelf (COTS) processors to host the MORA management interfaces consisting of web services and Syslog-based health publishing.

A human machine interface (HMI) was run on a smart display to enable man-in-the-loop management of all MORA devices. An expert system running on a headless shared processing unit (SPU) completed the reference implementation and provided automated monitoring and system recovery.

Experimental Scenarios

A lab demonstration was conducted at CERDEC I2WD in November 2013 to validate the MORA architecture. The reference implementation was used to demonstrate how MORA’s features can be leveraged across 4 operationally relevant scenarios, described below:

1. *Simultaneous operation of a communications waveform and jamming waveform along separate low-loss RF paths from SDRs to Radioheads.* Via the touchscreen interface, SDR operation was toggled on and off, RF paths were selected, and Radiohead filter bands were tuned. Device status fields such as temperature were continually updated and displayed graphically. Figure 6 illustrates normal operation in this baseline scenario.

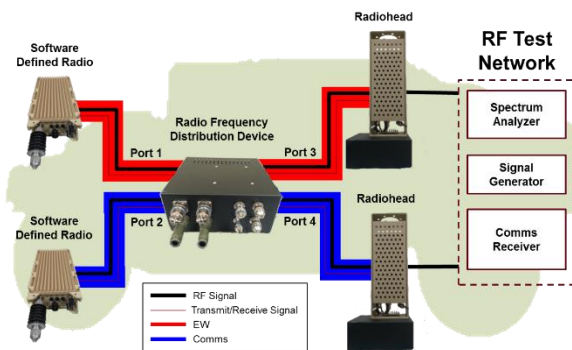

Figure 6. The MORA reference implementation includes concurrent operation of EW and communications waveforms.

2. *Automatic Radiohead failover and recovery.* When one of the Radioheads was disconnected to simulate failure, the fault was detected by the expert system, which automatically reconfigured RF paths such that the SDR running the highest priority waveform was connected to the remaining functional Radiohead. Figure 7 illustrates this failover configuration. Upon restoring operation of the faulted Radiohead, the idled low priority SDR was automatically turned back on and its RF routed to the resurrected Radiohead. This returned the system to normal operation.

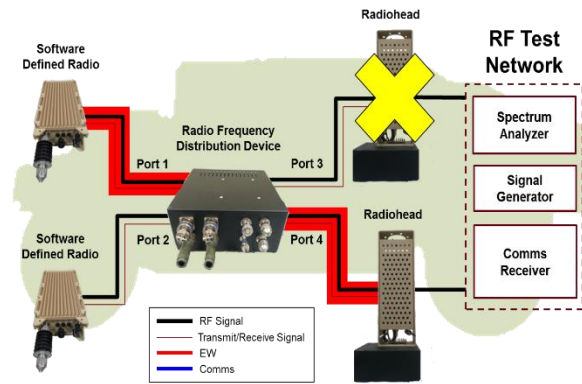

Figure 7. Pooled redundancy enables automated failover to mitigate Radiohead failure and restore the highest priority mission.

3. *Automatic SDR failover and recovery.* Same concept as the Radiohead failover, except in this case the SDR running the high priority waveform was disconnected. The expert system automatically addressed the problem by commanding the remaining functional SDR to unload the low priority waveform and load the high priority one without need for human intervention or rebooting. Figure 8 illustrates this failover configuration.

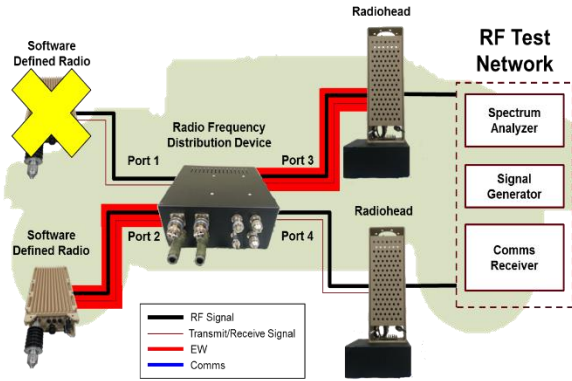

Figure 8. Pooled redundancy enables automated failover to mitigate SDR failure and restore the highest priority mission.

4. Transmit diversity. The use of multiple spatially separated antennas to transmit the same waveform is a common way to deal with the effects of RF fading in harsh multipath environments. A simple implementation of transmit diversity was implemented by rapidly (once per millisecond) switching the SDRs' RF path between the pair of Radioheads via the RFDD. Figure 9 illustrates how this was demonstrated for both jamming and communications waveforms.

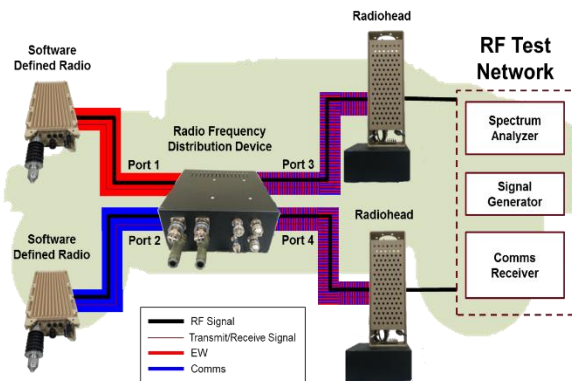

Figure 9. MORA enables time switched transmit diversity without requiring additional antennas.

HARDWARE/SOFTWARE CONVERGENCE

Current C4ISR/EW systems use single purpose hardware (HW) and software (SW) which lack flexibility and compete for limited resources on the platform (i.e., space, power, and spectrum). CERDEC is defining a converged architecture at the hardware, software, and network layers that will enable interoperability and rapid insertion of new capabilities. Sharing of hardware and software components will reduce the SWaP footprint of C4ISR and EW systems. Well-defined components with open interfaces will not only allow technology refresh to keep pace with emerging threats, but permit capabilities that are innovative but unplanned to be rapidly implemented. CERDEC is working with industry and academic partners to define and mature the associated specifications during the FY14-17 timeframe by developing reference implementations within the converged architecture. Resulting standards will then be transitioned to the acquisition community for inclusion in future solicitations and requirements.

The architecture selected consists of (1) VICTORY to provide on-the-wire interoperability via a network-based data bus, (2) MORA to provide a hardware decomposition for radio systems, (3) REDHAWK to provide a software framework to maximize portability of radio waveforms, and (4) OpenVPX to provide a hardware form factor that minimizes SWaP. HW/SW Convergence activities will mature these standards through a series of lab and vehicle-based demonstrations that validate the architecture for capabilities including EW, Communications, Sensors, Mission Command (MC), and Position, Navigation and Timing (PNT). The three phased approach has already started with a proof-of-principle demonstration that will verify these capabilities can be realized on 3U cards using

a COTS backplane. The next phase will validate a Department of Defense (DoD) specific backplane that addresses considerations such as flexibility, red/black separation, and phase coherent operations. The resulting design will maximize backplane utilization for both digital (e.g., Ethernet) and analog (e.g., coaxial RF) interconnects in an effort to minimize front

panel connectors and facilitate two-level maintenance. The third and final phase will leverage the newly established open interfaces to demonstrate compatibility, interoperability, and resource sharing across capabilities. Figure 10 summarizes the objectives of each phase in CERDEC's HW/SW Convergence plan.

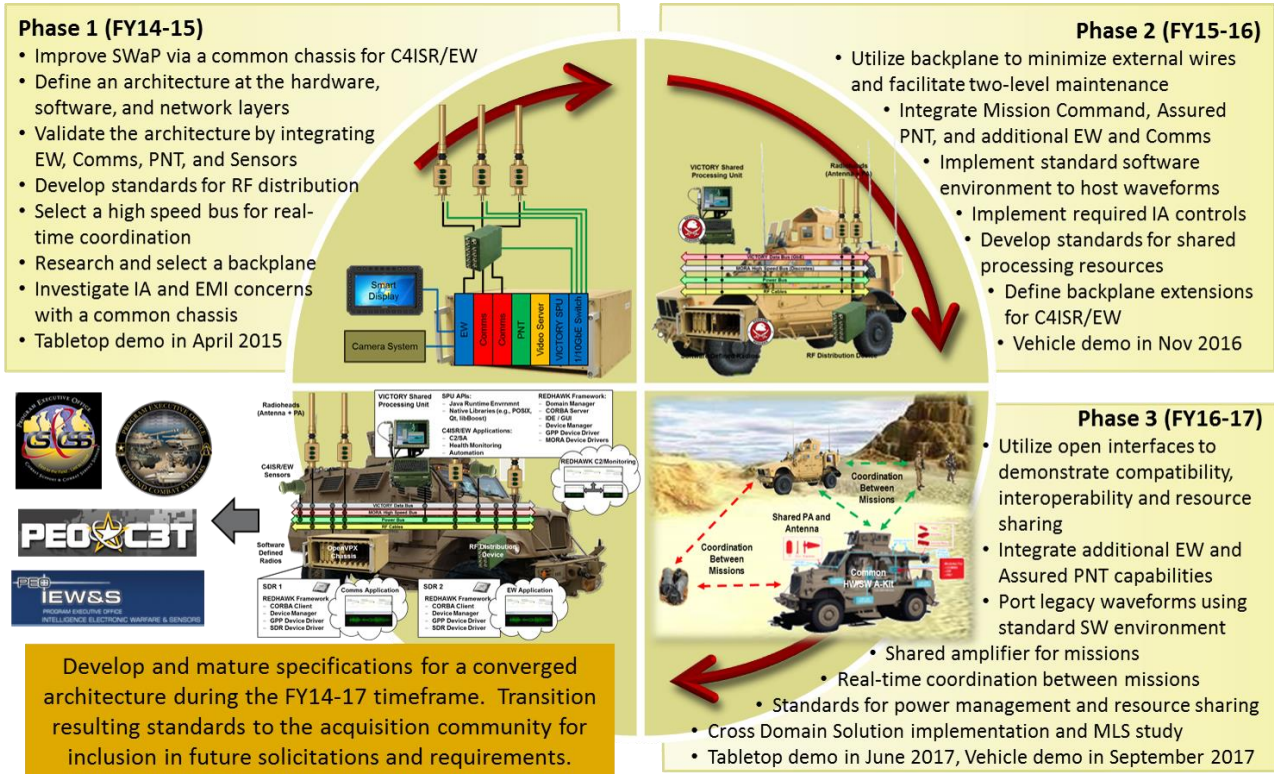

Figure 10. HW/SW Convergence activities will mature the architecture and associated specifications during the FY14-17 timeframe.

CONCLUSION

The MORA approach is not new technology, but rather a new way to integrate high technology readiness level (TRL) components that exist today. Standardization of a distributed architecture provides significant SWaP and cost advantages, while enabling incremental capability upgrades to platforms with existing electronics. System integrators now have increased flexibility to select and more easily integrate best of breed

technology that ultimately results in a more valuable product to the warfighter. All of this is accomplished with minimal added complexity and cost by exposing interfaces that are already present in most modern radio systems.

REFERENCES

- [1] *Jonathan E. Green and Michael P. Johnson. "Harmonizing Communications and Electronic Warfare." White Paper delivered to PMEW (2011).*
- [2] *Vehicular Integration for C4ISR/EW Interoperability (VICTORY) Architecture, Version: A3, 23 May 2013.*
- [3] *Vehicular Integration for C4ISR/EW Interoperability (VICTORY) Standard Specifications, Version 1.6.1, 30 June 2014.*
- [4] *VICTORY Training Material, 27 June 2013.*